

# CITY-BIKER QL3

## Shoulder Bag with Quick-Lock3 system



Test result „Super“  
Trekking Bike (D) 2/2013



Internal view: fixing of shoulder strap while cycling

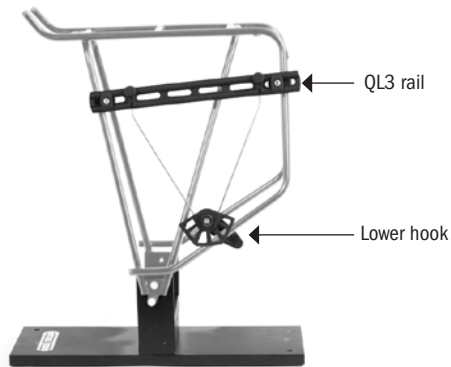

QL3 mounting elements

Height cm/in.	Width cm/in.	Depth cm/in.	Vol. l/cu.in.	Weight g/oz.
42/16,5	32/12,6	10/3,9	10/610	900/31.8

- Vertically-shaped shoulder bag with flap (single bag)
  - Quick-Lock3 mounting system with two upper hooks only
  - Single-handed operation
  - Clean uncluttered back of the bag
  - Reinforced material at base and rear side
  - Padded shoulder strap
  - Internal liner with zippered inner pocket
  - Snaphook for keys
  - Pen slot
  - Size fits DIN A4 documents and 13.3" laptops
  - Optional accessories: Notebook sleeve 13.3"
  - Shoulder strap must be fixed under flap prior to biking!
- Bag comes with QL3 mounting elements and shoulder strap

PRODUCT-INFO

Please find information on IP symbols on our info sheet or at [www.ortlieb.com/ip-symbols](http://www.ortlieb.com/ip-symbols)

City-Biker\_QL3\_03\_2013