

# PRODUCT INFO



## CITY-BIKER QL3.1

Shoulder Bag with QL3.1 system

QL3.1 system

IP 53

PS33

PVC free



Test result „Super“  
Trekking Bike (D) 2/2013



Internal view: fixing of shoulder strap while cycling

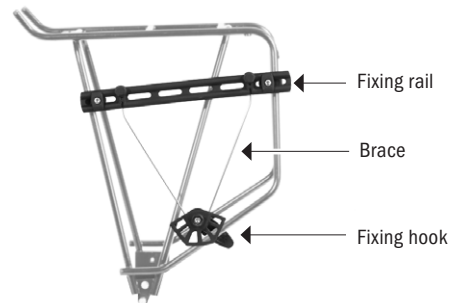
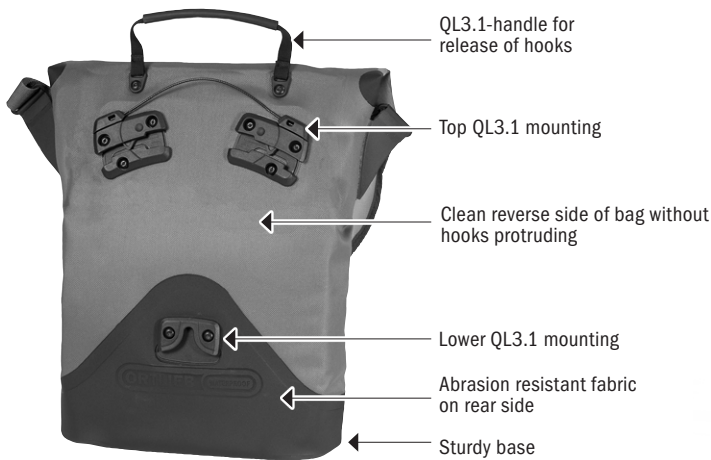

QL3/QL3.1 mounting elements

height cm/in.	width cm/in.	depth cm/in.	vol L/cu.in.	weight g/oz.
42/16.5	32/12.6	10/3.9	10/610	900/31.8

### SPECIFICATIONS:

- + Vertically-shaped shoulder bag with flap (single bag)
- + QL3.1 mounting system with 3 mounting positions
- + Single-handed operation
- + Clean uncluttered back of the bag
- + Reinforced material at base and rear side
- + Padded shoulder strap
- + Internal liner with zippered inner pocket
- + Snaphook for keys
- + Pen slot
- + Size fits DIN A4 documents and 13.3" laptops

**Contents:** Bag comes with QL3.1 mounting elements and shoulder strap

**Optional accessories:** Notebook sleeve 10"/13.3"

**Attention:** Shoulder strap must be fixed under flap prior to biking!

**Note:** For reaching protection standard IP53 (5=dust protected, 3=protected against splash water coming 60° to the vertical) the roll closure must be entirely closed.