

**OPTION 3**

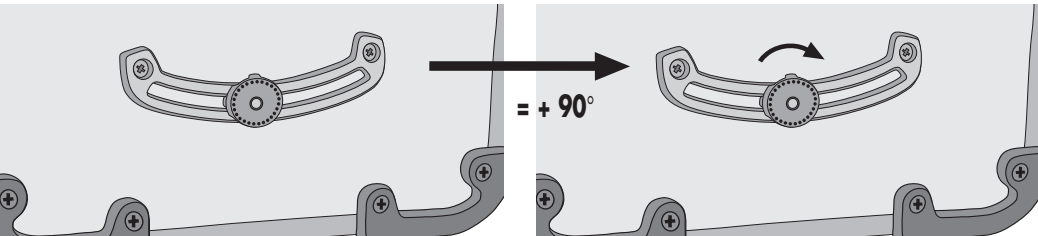
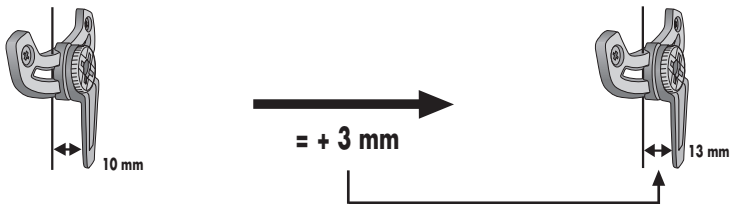

1.) 100 Km (60 Miles)  
 2.) 500 km (300 Miles)  
 3.) 1000 km (600 Miles)  
 4.) 1500 km (900 Miles)  
 .... etc.

**OPTION 2**

**DOWNTOWN QL2.1**



- DE MONTAGEANWEISUNG:**
- GB ASSEMBLY INSTRUCTIONS:**
- FR INSTRUCTIONS DE MONTAGE:**
- IT ISTRUZIONI DI MONTAGGIO:**
- NL MONTAGE HANDLEIDING:**
- DK MONTERINGSVEJLEDNING:**
- ES INSTRUCCIONES DE MONTAJE:**
- SE MONTERINGSANVISNING:**
- NO MONTERINGSANVISNING:**
- FI ASENNUSOHJEET:**
- PL INSTRUKCJA MONTAZU:**
- JP** 換気の良い所に保管してください。

**QL2.1**

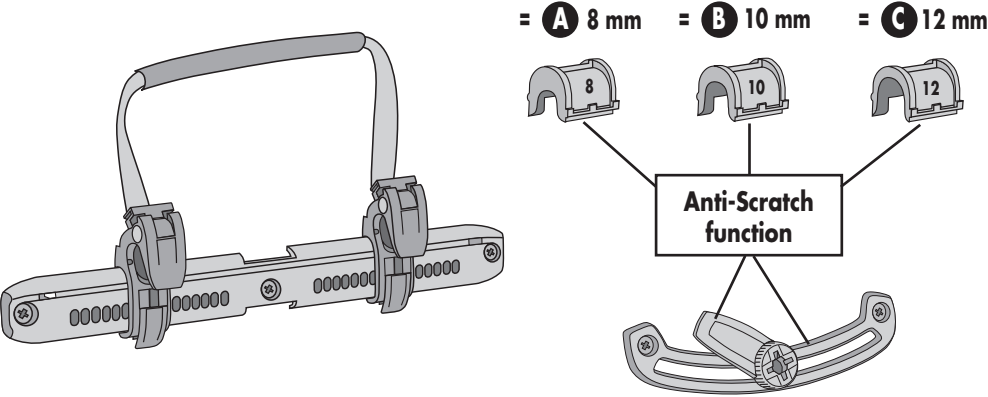

**ACCESSOIRES**

= + Art. #E193

= + Art. #E125 (I)

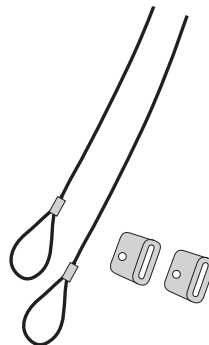
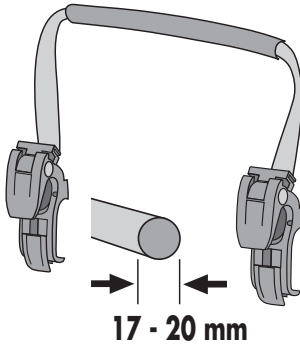

A

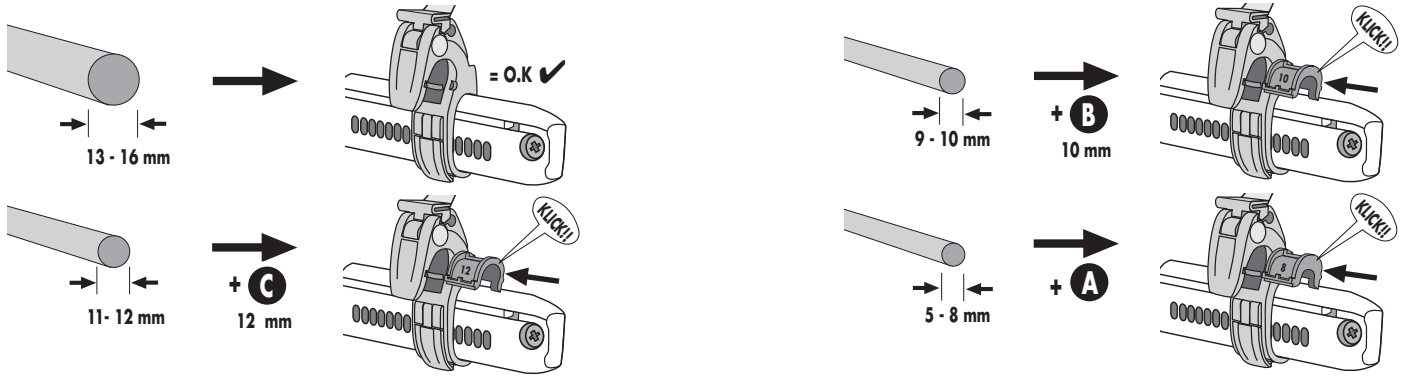

B

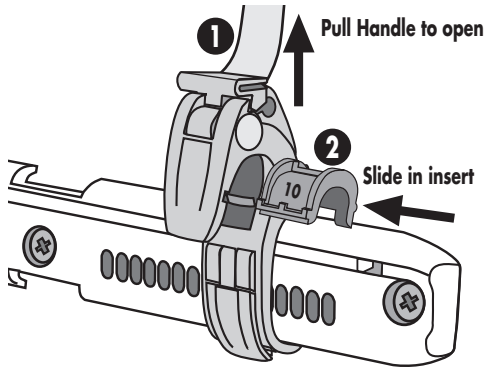

C

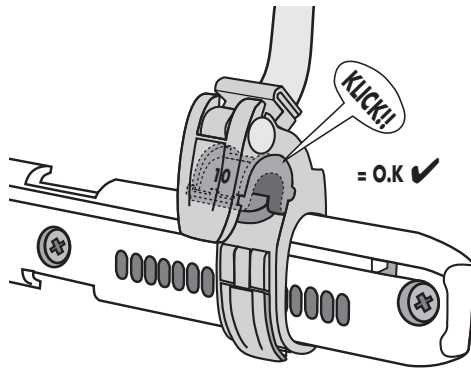

D

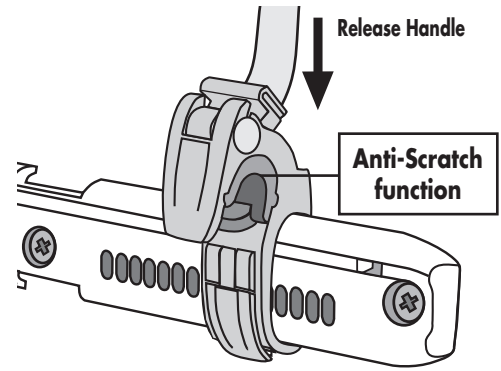

E

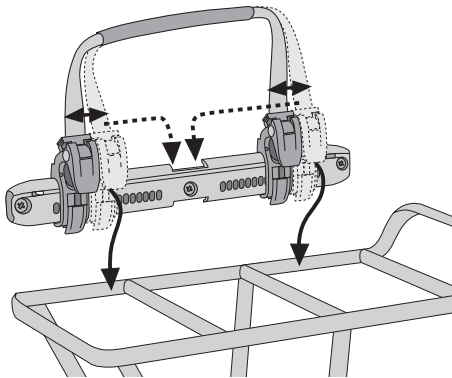

F

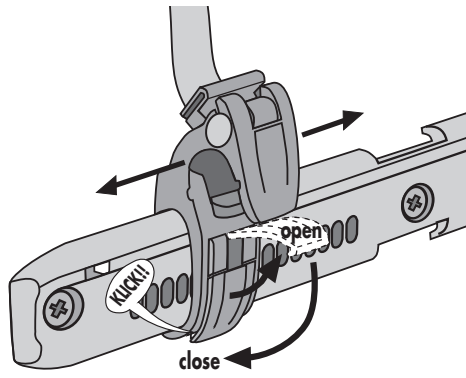

G

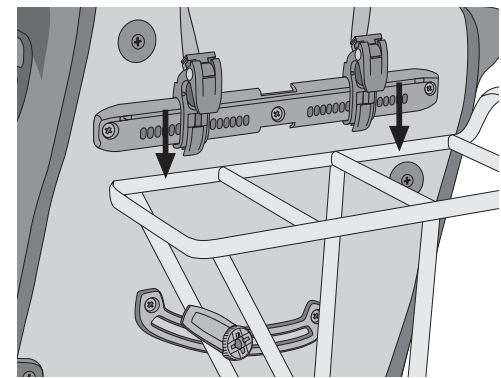

H

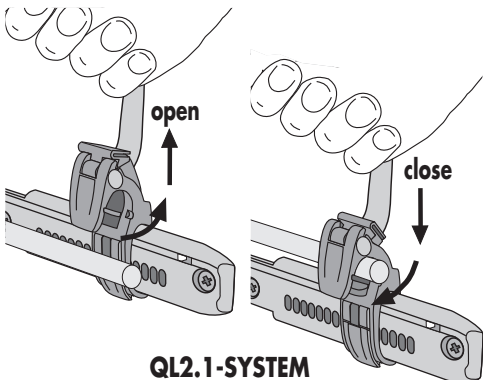

I

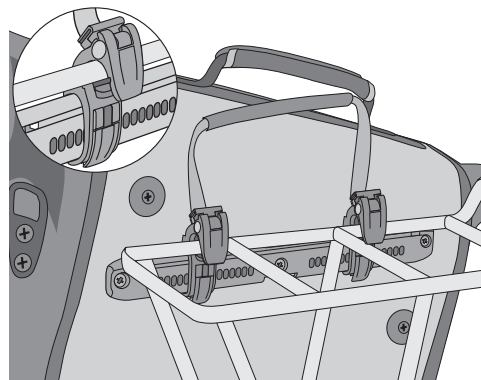

J

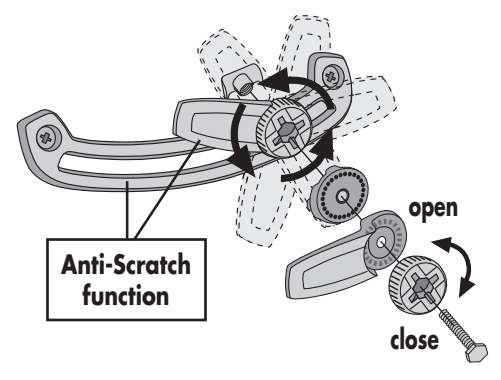

K

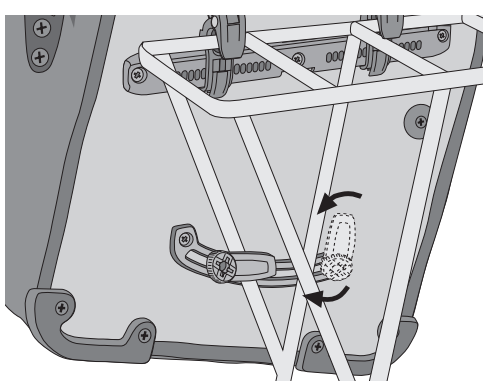

L

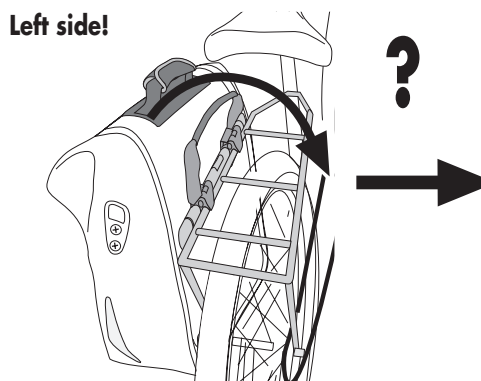

OPTION 1

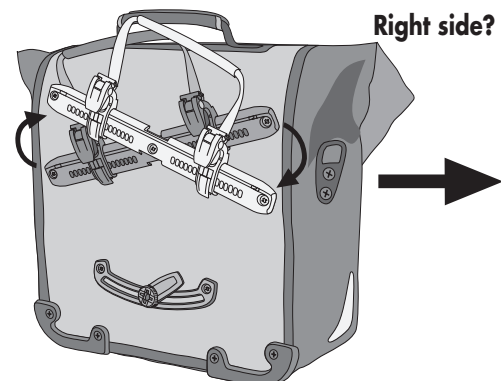

Left side!

Right side?